

Aberdeen Boat Club

2011 Southside Open Dinghy Regatta

3 & 4 December 2011 Sailing Instructions

1. Rules

- 1.1 The regatta will be governed by the 2009-2012 Racing Rules of Sailing (RRS), relevant Class Rules, the Aberdeen Boat Club (ABC) Southside Open Dinghy Regatta Notice of Race and these Sailing Instructions.
- 1.2 For all Laser Standard, Laser Radial and Laser 4.7 entrants, non-genuine Laser sails of correct size will be allowed provided that prior notification of size is given to the organizing authority before the competitors briefing scheduled for Sat 3 December at 10:30am.

2. Notices to Competitors

Notices to competitors will be posted on the Official Notice Board at ABC Middle Island Clubhouse.

3. Changes to Sailing Instructions

Any change to the sailing instructions will be posted on the official Notice Board before 9am on the day it will take effect, except that any change to the schedule of races will be posted by 6pm on the day before it will take effect.

4. Signals Made Ashore

Signals made ashore will be displayed from the flagpole located at the ABC Middle Island Clubhouse.

5. Programme and Schedule of Races

- | 5.1 | <u>Date</u> | | <u>Time</u> |
|-----|-------------------------------|--|-------------|
| | • Saturday 3 December, | Information Session: | 1030 |
| | | Racing, first possible Warning Signal: | 1155 |
| | | No Warning Signal After | 1555 |
| | • Sunday 4 December, | Information Session: | 0930 |
| | | Racing, first possible Warning Signal: | 1055 |
| | | No Warning Signal After | 1555 |
- 5.2 Any number of races may be sailed each day, subject to the Race Officers discretion, aiming for a minimum of 5 races and a maximum of 8 races for the regatta. 3 races will constitute a series.
 - 5.3 Flag AP displayed on the Race Committee Boat at the finish line indicates that another race will commence as soon as possible upon completion of the current race. This flag will be removed one minute prior to the new warning signal.
 - 5.4 Class Flags
 - Division A: flag E
 - Division B: flag U
 - Division C: Optimists: flag Q
 - Division D: 29ers: flag V

6. Racing Areas

The racing areas will be selected from around Middle Island: Repulse Bay, Chung Hum Kok Bay or Stanley Bay. Attachment A shows the location of the racing areas and this will be notified to competitors by the race committee hoisting signals ashore using the appropriate flag not less than 90 minutes before the first warning signal of the day.

Area G (Green Flag)	Area Outside Middle Island / Repulse Bay
Area Y (Yellow flag)	Chung Hom Kok
Area R (Red Flag)	Stanley

7. The Courses

Courses will be chosen from those shown in Attachment A.

8. The Start

- 8.1 Races will be started by using Rule 26 with the warning signal made five minutes before the starting signal. The start signal will be the warning signal for the succeeding class.
- 8.2 The starting line will be between a staff displaying an orange flag on the Race Committee Boat at the starboard end and the port-end start mark. A small orange buoy may be laid as an Inner Distance Mark.
If laid, boats starting shall leave this mark on the same hand as the Race Committee Boat.

9. The Finish

The finishing line will be between a staff displaying a blue flag on the Race Committee Boat and the nearby finish mark. A small orange buoy may be laid as an Inner Distance Mark.
If laid, boats finishing shall pass between the finish mark and the Inner Distance Mark.

10. Time Limits

- 10.1 The time limit for the first boat in each division to sail the course and finish shall be 60 minutes.
- 10.2 Boats failing to finish within 20 minutes after the first boat (Divisions A and B) and 10 minutes Division C&D) sails the course and finishes will be scored Did Not Finish (DNF) unless the Race Office finishes them on the water as set out in paragraph 10.3 below. This changes RRS rules 35 and A4.
- 10.3 When more than half the boats have finished the Race Office may finish the balance of the boats at the last mark, or on the course. The method of finishing and the finish positions awarded each boat thereby will be determined by the Race Officer on behalf of the race committee. This changes RRS rule 28.

11. Protests

- 11.1 Protest forms are available at the race office, located at the rear of the club house. Protests and requests for redress or reopening shall be delivered there within the protest time limit.
- 11.2 The protest time limit is 120 minutes after the last boat has finished the last race of the day.
- 11.3 Protests must be accompanied by a HK\$200 fee which will be refunded if the protest goes ahead.
- 11.4 Notices will be posted no later than 30 minutes after the protest time limit to inform competitors of the time and place of hearings in which they are parties or named as witnesses.
- 11.5 On the last day of racing any request for reopening a hearing shall be delivered:
 - (a) Within the protest time limit if the requesting party was informed of the decision on the previous day:
 - (b) No later than 30 minutes after the requesting party was informed of the decision on the last day of racing. This changes rule 66.
- 11.6 On the last day of racing a request for redress based on a protest committee decision shall be delivered no later than 30 minutes after the decision was posted. This changes rule 62.2.

12. Scoring

- 12.1 Scores in Divisions A & B will be calculated on corrected time using RYA PY handicaps
- 12.2 Scores in Division C and D will be based on finishing places.
- 12.3 A minimum of 5 races and a maximum of 8 races is the target for the regatta, with three races being required to be completed to constitute a series.
- 12.4 Rule A2 is changed as follows:
When four or fewer races have been completed, a boat's series score will be the total of her race scores.
When five races or more have been completed, a boat's series scores will be the total of her race scores excluding her worst score.

13. Safety Regulations

- 13.1 Competitors are reminded of RRS Rule 4, decision to race.
- 13.2 Personal Flotation Devices (PFDs) in good serviceable condition shall be worn at all times whilst on the water.
- 13.3 A check-out /check-in registration sheet will be placed at ABC Middle Island Race Office. Failure to check- out or check- in after the race may result in a penalty of 10 points without a hearing. This changes rules A4 & A5.

14. Official Boats

Race Control boats will display a white flag.

15. Support Boats

Team leaders, coaches and other support personnel shall stay well clear away from areas where the dinghies are racing from the time of the first preparatory signal to the finish of the race.

16. Trash Disposal

Boats shall not put trash in the water. Trash may be placed aboard support and race committee boats.

17. Prizes

Prizes will be given as per the Notice of Race.

18. Disclaimer of Liability

Competitors participate in the regatta entirely at their own risk. See Rule 4, Decision to Race. The organizing authority will not accept any liability for material damage or personal injury or death sustained in conjunction with or prior to, during, or after the regatta.

19. Insurance

Third-party liability insurance is the responsibility of each participating boat

Supporting the ABC Southside Regatta:

29er
Hong Kong



SLAM

**FRAGRANT
HARBOUR**

Sailing Areas

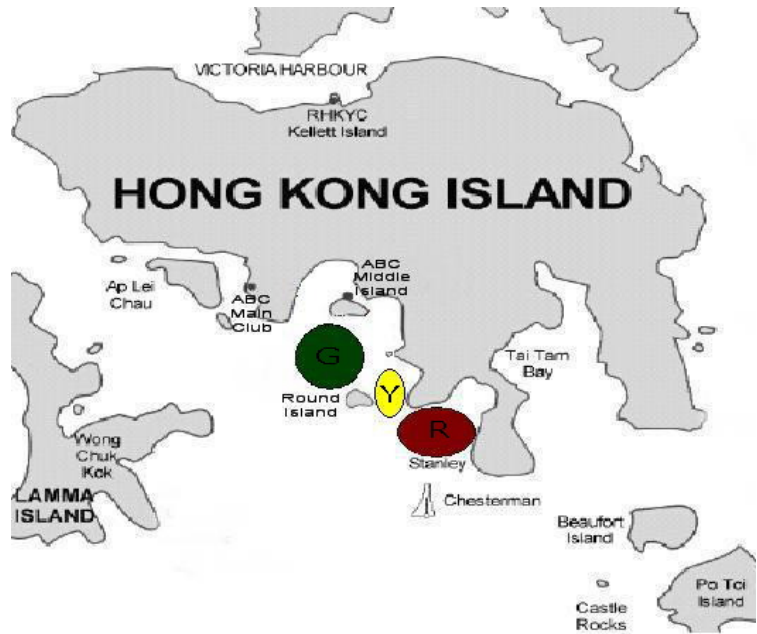

Attachment B
 ABC Southside Open Dinghy Regatta 2011
Courses

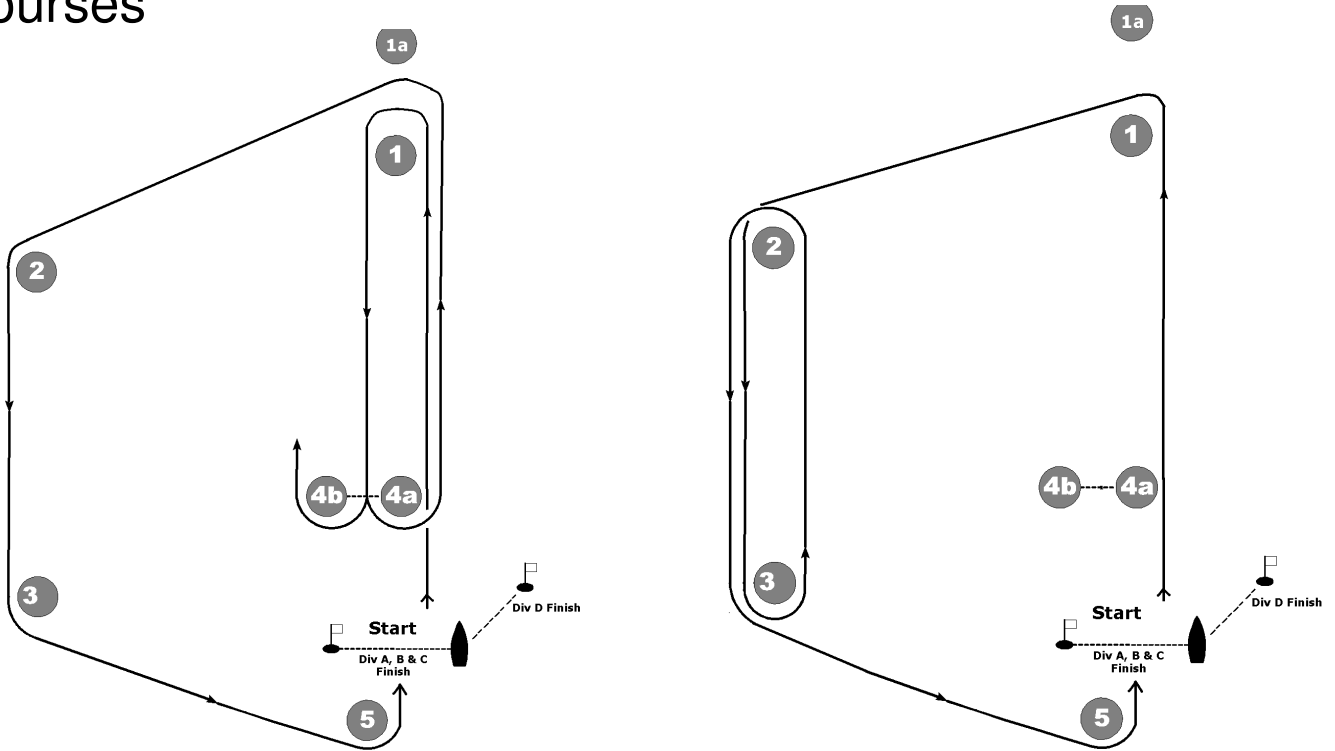

Marks 1, 2, 3, 5 will be large black buoys
 Marks 4a, 4b, 1a will be large orange buoys
 The start / finish buoy for Div A, B & C will have a white covering and for Div B a flag

Course 1 Start, 1, 4a/4b, 1, 2, 3, 5, Finish ("Inner loop")	Course 4 Start, 1, 2, 3, 2, 3, 2, 3, 5, Finish ("double outer loop")
Course 2 Start, 1, 4a/4b, 1, 4a/4b, 1, 2, 3, 5, Finish ("double inner loop")	Course 5 Start, 1a, 4a/4b, 1a, 4a/4b, Finish (Div B) ("double windward-leeward")
Course 3 Start, 1, 2, 3, 2, 3, 5, Finish ("outer loop")	Course 6 Start, 1, 2, 3, 5, Finish ("circuit")