

Aberdeen Boat Club
2014 Southside Open Dinghy Regatta
6 & 7 December 2014
Sailing Instructions

1. Rules

- 1.1 The regatta will be governed by the 2013-2016 Racing Rules of Sailing (RRS), the HKSF prescriptions, relevant Class Rules, the Aberdeen Boat Club (ABC) Southside Open Dinghy Regatta Notice of Race and these Sailing Instructions, with succeeding items taking precedence.
- 1.2 For all Laser Standard, Laser Radial, Laser 4.7, Laser Pico and Topper entrants, non-genuine sails of correct size will be allowed provided that prior notification is given to the organizing authority before the competitors briefing.

2. Notices to Competitors

Notices to competitors will be posted on the Official Notice Board at ABC Middle Island Clubhouse.

3. Changes to Sailing Instructions

Any change to the sailing instructions will be posted on the official Notice Board before 9am on the day it will take effect, except that any change to the schedule of races will be posted by 6pm on the day before it will take effect.

4. Signals Made Ashore

Signals made ashore will be displayed from the flagpole located at the ABC Middle Island Clubhouse.

5. Programme and Schedule of Races

- 5.1
- | <u>Date</u> | | <u>Time</u> |
|-------------------------------|--|-------------|
| • Saturday 6 December, | Information Session: | 09.30 |
| | Racing, first possible Warning Signal: | 10.55 |
| | No Warning Signal After | 15.55 |
| • Sunday 7 December, | Information Session: | 09.30 |
| | Racing, first possible Warning Signal: | 10.55 |
| | No Warning Signal After | 15.55 |
- 5.2 Any number of races may be sailed each day, subject to the Race Officer's discretion, aiming for a minimum of 5 races and a maximum of 8 races for the regatta. 3 races will constitute a series.
- 5.3 Flag AP displayed on the Race Committee Boat at the finish line indicates that another race will commence as soon as possible upon completion of the current race. This flag will be removed one minute prior to the new warning signal.

6. Flags

6.1 Class Flags:

Division A	Flag E
Division B (including 2.4mR class)	Flag J
Division C Optimist	Flag Q
Division D 29er	Flag V
Division E Access / Hansa 303W	Flag W
Division F Formula 18 & other Multihull	Flag T
Division G Hobie 16	Flag R

7. Racing Areas

The racing areas for Div A, B, C and E:

Area G (Green Flag)	Area Outside Middle Island / Repulse Bay
Area Y (Yellow Flag)	Chung Hom Kok Bay
Area R (Red Flag)	Stanley

This and this will be notified to competitors by the race committee hoisting signals ashore using the appropriate flag not less than 90 minutes before the first warning signal of the day.

Additional racing areas for Div D, F and G:

Divisions D, F and G may race in the areas above or in addition the following areas:

Area OS = Outer Stanley Bay

Area PT = West of Po Toi

This will be notified to competitors by the race committee on or before 6pm the day previous to racing by announcement on the ABC website, the official noticeboard and by email to all registered competitors in applicable divisions.

8. The Courses

Courses will be chosen from those shown in Attachment B (Div A, B, C and E) and Attachment C (Div D, F & G)

9. The Start

- 9.1 Races will be started by using Rule 26 with the warning signal made five minutes before the starting signal. The start signal will be the warning signal for the succeeding class.
- 9.2 The starting line will be between a staff displaying an orange flag on the Race Committee Boat at the starboard end and the port-end start mark. A small orange buoy may be laid as an Inner Distance Mark. If laid, boats starting shall leave this mark on the same hand as the Race Committee Boat.
- 9.3 If Flag U has been displayed as the preparatory signal, no part of a boat's hull, crew or equipment shall be in the triangle formed by the ends of the Starting line and the first mark during the last minute before her starting signal. If a boat breaks this rule and is identified she shall be disqualified without a hearing but not if the race is restarted or resailed or postponed or abandoned before the starting signal. This changes rule 26.

10. The Finish

The finishing line for **Divisions A, B, C and E** will be between a staff displaying an orange flag on the Race Committee Boat at the starboard end and the port-end Finish Mark detailed in Attachment B. A small orange buoy may be laid as an Inner Distance Mark.

The finishing line for **Divisions D, F and G** will be between a staff displaying an orange flag on the Race Committee Boat at the starboard end and the port-end Finish Mark as shown in Attachment C. If laid, boats finishing shall pass between the finish mark and the Inner Distance Mark.

11. Propulsion

For the 29er Class if the wind is consistently 10 knots or above, measured at deck level, the Race Committee may permit "pumping, rocking and ooching" by displaying the International Code Flag "O" before or with the warning signal, and these actions are permitted from the preparatory signal. This changes rules 42.1, 42.2(a), 42.2(b) and 42.2(c).

12. Time Limits

- 12.1 The time limit for the first boat in **Divisions A, B, C and E** to sail the course and finish shall be 60 minutes. The time limit for the first boat in **Divisions D, F and G** to sail the course and finish shall be 50 minutes.
- 12.2 Boats failing to finish within 20 minutes after the first boat (**Divisions A, B, C and E**) and within 10 minutes after the first boat (**Divisions D, F and G**) sails the course and finishes will be finished on the water in the place they are currently in and return to the start for the next race. (if applicable)
This changes Rules 34, 62.1a, A4 and A5.

13. Penalty Turns

- 13.1 For Divisions F and G RRS 44.1 is changed so that the Two-turn penalty is replaced by the One-turn penalty

14. Exoneration Penalty

- 14.1 A boat that may have broken a rule may, after finishing the race concerned and before the start of a related protest hearing, notify the Race Committee that she accepts a 20% scoring penalty, except the minimum scoring penalty shall be 3 places. This changes Rule 44.3(c).
- 14.2 The Exoneration Penalty is not available for a breach of Rule 2 or of class rules or for gross misconduct under Rule 69. Nor is it available to a boat that caused injury or serious damage, or gained a significant advantage by her breach of the rules:
- 14.3 When an Exoneration Penalty is accepted,
 - a) neither the boat nor the Protest Committee may then revoke or remove the penalty
 - b) the boat shall not be penalised further in a protest hearing when the Protest Committee decides that the exoneration penalty was appropriate to the facts found and the appropriate rules.

15. Protests

- 15.1 Protest forms are available at the race office, located at the rear of the Middle Island club house. Protests and requests for redress or reopening shall be delivered there within the protest time limit.
- 15.2 The protest time limit is 90 minutes after the last boat has finished the last race of the day.
- 15.3 Protests must be accompanied by a HK\$300 fee which will be refunded if the protest is successful.
- 15.4 Notices will be posted no later than 30 minutes after the protest time limit to inform competitors of the time and place of hearings in which they are parties or named as witnesses.
- 15.5 On the last day of racing any request for reopening a hearing shall be delivered:
 - (a) Within the protest time limit if the requesting party was informed of the decision on the previous day:
 - (b) No later than 30 minutes after the requesting party was informed of the decision or the decision was posted on the last day of racing. This changes rule 66.
- 15.6 On the last day of racing a request for redress based on a protest committee decision shall be delivered no later than 30 minutes after the decision was posted. This changes Rule 62.2.

16. Scoring

- 16.1 Scores in Divisions A & B will be calculated on corrected time using RYA PY handicaps
- 16.2 Scores in Divisions C, D, E and G will be based on finishing places
- 16.3 Scores in Division F will be calculated on corrected time using SCHRS handicap rating system.
- 16.4 A minimum of 5 races and a maximum of 8 races is the target for the regatta, with three races being required to be completed to constitute a series.
- 16.5 Rule A2 is changed as follows:
When four or fewer races have been completed, a boat's series score will be the total of her race scores. When five races or more have been completed, a boat's series scores will be the total of her race scores excluding her worst score.

17. Safety Regulations

- 17.1 Competitors are reminded of RRS Rule 4, decision to race.
- 17.2 Personal Flotation Devices (PFDs) in good serviceable condition shall be worn at all times whilst on the water.
- 17.3 A check-out /check-in registration sheet will be placed at ABC Middle Island Race Office. Failure to check- out or check- in after the race may result in a penalty of 10 points without a hearing. This changes rules A4 & A5.
- 17.4 Boats competing in divisions F and G are not required to complete the check-out / check-in system.
- 17.5 Boats competing in divisions F and G who sail to and from the race area from their own club should arrange their own safety cover to and from the race area, ABC safety cover will be available only for the area of racing

18. Regulations for crossing the Lamma Shipping Channel

- 18.1 No boat in any division is permitted to enter or pass closer than 100m to the Lamma Shipping Channel. Any boat doing so shall be disqualified.

19. Official Boats

Race Control boats may display a white flag.

20. Coach Boats

Coach boats shall stay outside areas where boats are racing from the time of the preparatory signal for the first class to start until all boats have finished or the Race Committee signals a postponement, general recall or abandonment.

21. Trash Disposal

Boats shall not put trash in the water. Trash may be placed aboard support and race committee boats.

22. Prizes

Prizes will be given as per the Notice of Race.

23. Disclaimer of Liability

Competitors participate in the regatta entirely at their own risk. See Rule 4, Decision to Race. The organizing authority will not accept any liability for material damage or personal injury or death sustained in conjunction with or prior to, during, or after the regatta.

24. Insurance

Third-party liability insurance is required and is the responsibility of each participating boat

Supporting the ABC Southside Regatta:



Official
Clothing
supplier:



Attachment A: ABC Southside Open Dinghy Regatta 2014 Sailing Areas

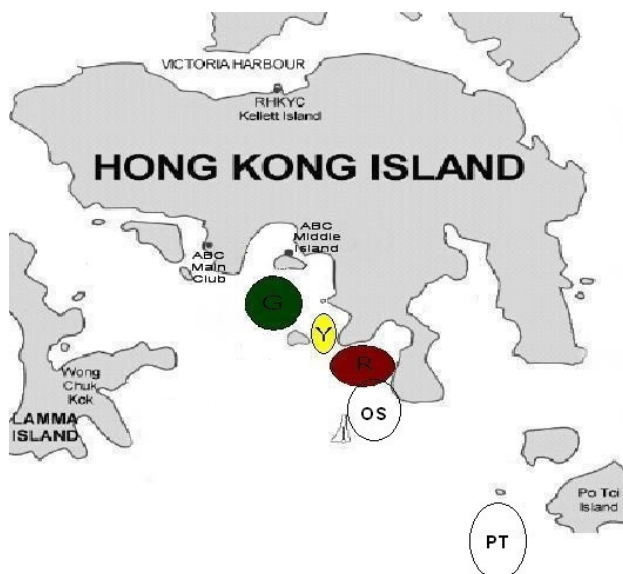

G = Middle Island / Deep Water Bay

Y = Chung Hom Kok

R = Stanley Bay

OS = Outer Stanley Bay

PT = Po Toi

Attachment B

ABC Southside Open Dinghy Regatta 2014
Courses – Div A, B, C and E

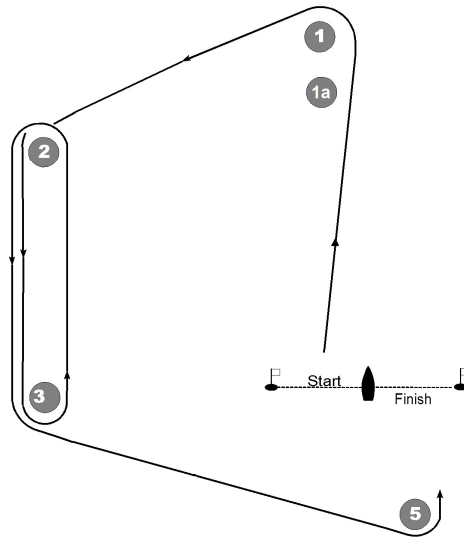
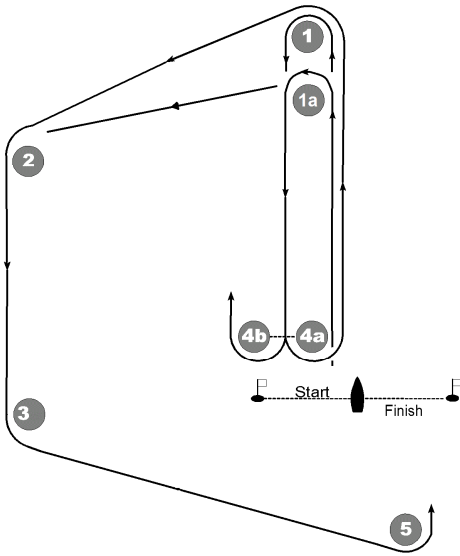

Course 1 Start, 1a, 4a/4b, 1a, 2, 3, 5, Finish ("Inner loop")	Course 4 Start, 1, 2, 3, 2, 3, 2, 3, 5, Finish ("double outer loop")
Course 2 Start, 1a, 4a/4b, 1a, 4a/4b, 1a, 2, 3, 5, Finish ("double inner loop")	Course 5 Start, 1, 2, 3, 5, Finish ("circuit")
Course 3 Start, 1, 2, 3, 2, 3, 5, Finish ("outer loop")	

Attachment C

ABC Southside Open Dinghy Regatta 2014
Courses – Div D, F & G

Course 6

Start, 1a, 2a/2b, 1a, 2a/2b, Finish
("double windward-leeward")

Course 7

Start, 1a, 2a/2b, 1a, 2a/2b, 1a, 2a/2b, Finish
("triple windward-leeward")

